



3 phase,60HZ@1800RPM

Prime power	KVA	455
	KW	364
Standby power	KVA	500
	KW	400
Voltage	V	440/254
Ampere	A	655.7



Notes:

- 1) Ambient condition: 1,000 m,25°C
- 2) Available in following voltages:220/127,208/120,416/240,440/254,460/266,480/277
- 3) Prime Power (PRP): Prime power is available for an unlimited number of annual hours in variable load application, in accordance with GB/T2820-97 (eqv ISO8528) ; A 10% overload capability is available for a period of 1 hour within a 12-hour period of operation.
Standby Power Rating (ESP): The standby power rating is applicable for supplying emergency power for the duration of a utility power interruption. No overload, utility parallel or negotiated outage operation capability is available at this rating.

Features

- | | |
|---|---|
| <ul style="list-style-type: none"> ● Engine (DOOSAN P158LE) ● Radiator 40°C max, fans are driven by belt, with safety guard ● Alternator: single bearing Mecc Alte alternator IP23, insulation class H/H) ● Main line circuit breaker ● Standard automatic control panel ● Batteries, rack and cable | <ul style="list-style-type: none"> ● 24V charge alternator ● Absorber ● Dry type air filter, fuel filter, oil filter ● Ripple flex exhaust pipe, exhaust siphon, flange, muffler ● User manual |
|---|---|

Performance Specification,Warranty and Criterion

Performance Specification		Telephone Influence Factor	
Voltage Regulation	≥±5%	TIF	<50
Voltage Regulation, Stead State	≤±1%	THF	<2%
Sudden Voltage Warp (100% Sudden Reduce)	≤+25%	Warranty Warranty is according to our standard conditions: a, 12 months, One year after installation; b, 1000 running hours (accumulated); subject to the earlier one.Service and parts are available from ENERGY360 or distributors in your location. Criterion <ul style="list-style-type: none"> ● Genset design comply to ISO8528/GB2820-97 ● Alternator design Compliance with GB755, BS5000, VDE0530, NEMAMG1-22, IED34-1, CSA22.2 and AS1359 standards 	
Sudden Voltage Warp (Sudden Increase)	≤-20%		
Voltage Stable Time (100% Sudden Reduce)	≤6S		
Voltage Stable Time (Sudden Increase)	≤6S		
Frequency Reduce	0-5% adjustable		
Frequency Regulation, Stead State	5%		
Frequency Waving	≤0.5%		
Sudden Frequency Warp (100% Sudden Reduce)	≤+12%		
Sudden Frequency Warp (Sudden Increase)	≤-10%		
Frequency Recovery Time (100% Sudden Reduce)	≤5S		
Frequency Recovery Time (Sudden Increase)	≤5S		

Engine specification			Alternator specification	
Brand	DOOSAN		Brand	Mecc Alte
Model	P158LE		Model	ECO40 1S4A
Air Intake System	Turbo, Air/Air cooling		Number of Phase	3
Fuel System	BOSCH P type fuel pump		Connecting Type	“Y” type connecting
Cylinder Arrangement	8 in “V”		Number of Bearing	1
Displacement	14.618L		Power Factor	0.8
BorexStroke	128×142 mm		Protection Grade	IP23
Compression Ratio	15.0:1		Altitude	≤1000m
Governor Type	Electronic Governor		Exciter Type	Brushless, self-exciting
Frequency Regulation, Steady State:	≤1.5%		Insulation Class, Temperature Rise	H/H
Starting system	E		Alternator Capacity	456KVA
Battery voltage	12VDC		Telephone Influence Factor (TIF)	<50
Fuel consumption(L/h)	100% load	102.5	THF	<2%
	75% load	74.7	Voltage Regulation, Steady State	≤±1%
	50% load	50.6	Alternator Efficiencies	93.6%
	25% load	28	Air Cooling Flow	0.8m3/s

Exhaust System		Air Intake System	
Exhaust Gas Flow	99.3m3/min	Max Intake Restriction	6.23kPa
Exhaust Temperature	505°C	Cooling Fan Air Flow	618m3/min
Max Back Pressure	5.9kPa	Intake Air Flow	36.9m3/min

Oil System		Cooling System	
Max Oil Capacity	21L	Total Coolant Capacity	80L
Oil Consumption	TBD	Thermostat	71-85°C
Max oil temperature	120°C	Max Water Temperature	103°C
Oil Pressure at Rated RPM	≥250kpa		



Control system

Deepsea brand DSE7320 (Standard)

Features:

- Auto Mains (Utility) Failure control module
- Remote PC and via SMS textalerts (with external modem)
- LED and LCD alarm indication
- Include USB, RS232 and RS485 ports
- Support for up to three remote display units
- Generator measurements (50/60 Hz): U1-U3, I1-I3, Hz, kW, kVAr, kWh
- Charge alternator failure alarm
- 3 phase Generator protections:
 - Over-/under voltage
 - Over-/under frequency
 - Current/voltage asymmetry
 - Overcurrent/overload
- Analog oil pressure, water temperature, fuel level, battery voltage, engine speed
- Load switching (load shedding and dummy load outputs)
- CAN and Magnetic Pick-up/Alt.sensing
- Automatic load transfer





Optional parts

Engine	Fuel System	Control System
● Heater	● Daily Fuel Tank	● Remote Control Panel
● Battery Charger	● Water Separator	● Auto Transfer Switch
	● Fuel Level Sensor	● Paralleling System
Alternator	Others	Data
● Anti Condensation Heater	● Soundproof Type	● Engine Parts Drawing List
● Drop CT (For Paralleling)	● Trailer Type	● Spare parts
● PMG	● Containerized Type	

Dimension and Weight

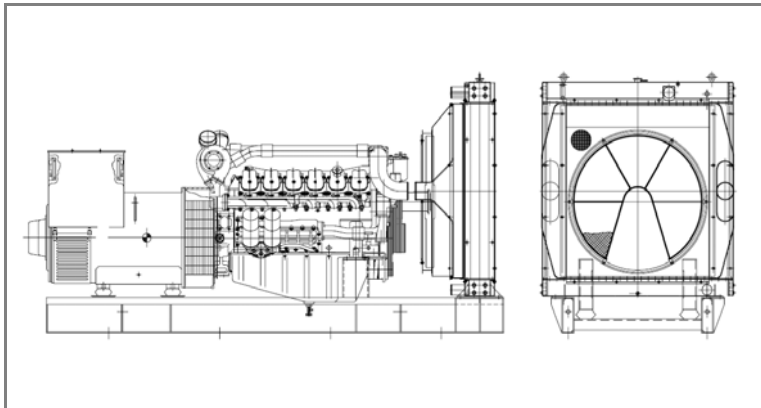

Open Type Genset

Dimension: 3100x1400x2000 mm

Weight: 3200 kg

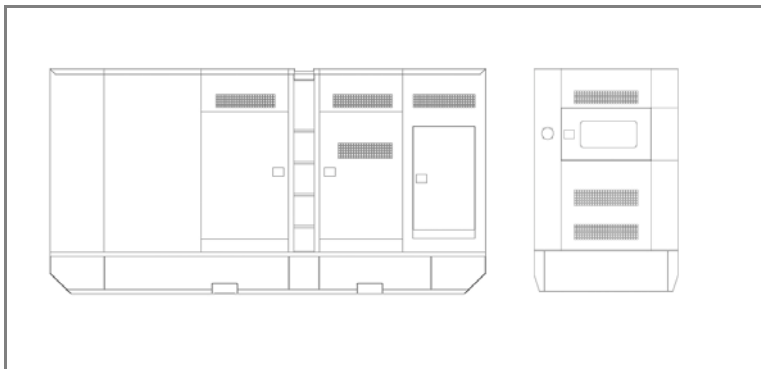

Soundproof Type Genset

Dimension: 4000x1500x2250 mm

Weight: 4000 kg

ENERGY360

Kra42 #54A 71 INT101 ITAGUI. PBX: (4)5600530

E-mail: info@energy360.com.co

